

LEFT HANDED DOORS  
OUTSIDE      INSIDE

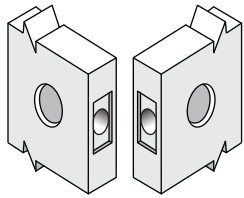

RIGHT HANDED DOORS  
INSIDE      OUTSIDE

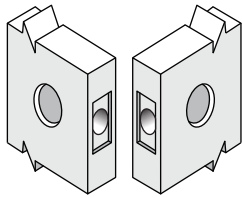

DRILL 1"(25mm) HOLE  
AT CENTER OF  
DOOR EDGE

FOLD ON DOOR EDGE  
FOLD ON DOOR EDGE

5/32"  
FACE PLATE THICKNESS

1"

1"

∅ 2-1/8" (54mm) or 1-1/2"  
diameter hole can be used

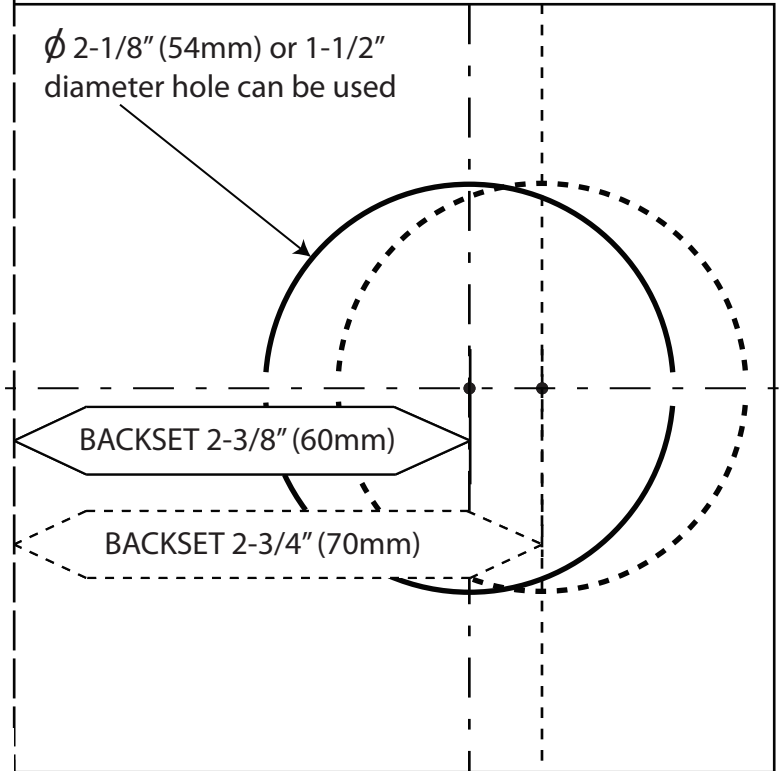
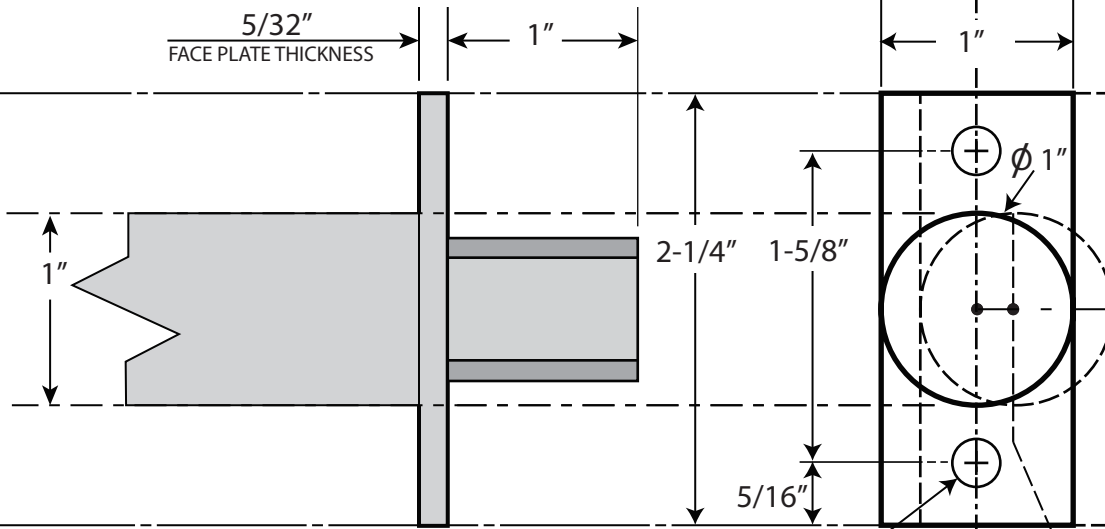

DRILL & TAP  
FOR #8-32 COMBO SCREW  
2 PLACES FOR METAL DOORS

1-3/4"  
(45mm)      1-3/8"  
(35mm)

**DOOR THICKNESS**

Supplied with plastic filler for 1-1/8" latch preparation

**1. MARK DOOR**

- A. Fold and apply to high edge of door bevel and mark center of door edge as indicated on template at the desired height from the floor.
- B. Mark center hole on door face through guide on template for 2-3/8" (60mm) or 2-3/4" (70mm) backset.

**2. DRILL HOLES**

- A. Drill thru door face as marked for lockset. It is recommended that holes be drilled from both sides to prevent splitting. Hole size is 2-1/8" (54mm) for standard installations.
  - B. Drill 1" (25mm) hole in center of door edge thru 2-1/8" (54mm) hole for latch.
- CAUTION: Check center of latch hole for alignment with strike center on jamb to ensure free movement of latch bolt.



6605 Flotilla St.  
City of Commerce  
CA 90040 USA  
Tel: (323) 888-6601  
FAX: (323) 888-6699  
Website: cal-royal.com  
Email: sales@cal-royal.com

ITEM NO.	DESCRIPTION	ANSI	SCALE	UNIT	VERSION
<b>LSD88</b>	<b>DOUBLE CYLINDER STANDARD DUTY DEADBOLT</b>	A156.2 Grade 3	1 : 1	inches (mm)	ver. 1.0 rev. 01/12
			PAGE 1 OF 1		BY: bteves/adg